



Metal detector / separator  
for mounting on vacuum fillers

## Technical data sheet

Version 02/20

### Users

- Food industry

### Application

- Outgoing goods inspection (quality management according to ISO 9000, HACCP, etc.)



GLOBAL. MAGNETIC. FORCE.™

## Arguments that convince

- The responsive and powerful pneumatic drive enables a very compact design despite the high throughput. In combination with the (optional) interval controller, the metal separator offers the highest degree of separation reliability with only minimal material loss.
- In most cases, these types of devices get damaged during transport to the cleaning chamber or during cleaning. This is why the sturdy tubular frame is designed to facilitate maneuvering and provide impact protection at the same time. The chassis is protected against tipping over and features four height-adjustable castor wheels along with a parking brake. A cover resistant to the ingress of high-pressure cleaning jets protects the display and reliably prevents water from entering the electronics housing.
- The integrated wash basket is another very useful feature. It is used for the storage of parts of the separation mechanism that get removed from the mechanism housing for cleaning, thus ensuring that you will never have to worry about losing parts again! A stainless-steel chain secures the mechanical parts against falling.
- With the right adapter, the metal separator can be connected to almost any vacuum filler. The working height can be adjusted quickly and precisely using the rotating spindle.
- You don't have to worry even if something "goes wrong" during the manufacturing process, as all components are designed to withstand pressures of up to 30 bar!
- One of the key features of this product is its functional reliability, which is why the metal separators boast an "extended system monitoring" capability. System monitoring is used to control the basic electrical functions, as well as the switching process of the discharge valve. This ensures that any malfunctions are reported reliably and without delay!
- The range of equipment options is rounded off by versions without a separating mechanism and versions with an extension axle for the operation of a downstream twist-off device. Because: "Individual production processes require tailor-made system solutions!"
- All parts in contact with food products are compliant with the applicable food safety standards.

## Detection accuracy

Ferrous (Fe) balls	Ø 0,9 mm
Non-ferrous (NFe) balls	Ø 1,2 mm
Stainless-steel (SS) balls	Ø 1,75 mm

- The values indicated above were determined under production conditions using various sausage meat recipes. In exceptional cases, there may be slight deviations as different device settings may be required.
- If you provide our Application Department with suitable product samples, we will be happy to inform you about the maximum possible scanning sensitivity values for the product.

## Standard scope of delivery

- A mobile base frame with an open-end wrench (NW 80)
- A detector coil with integrated evaluation electronics and a splash protection cover
- Power and connecting cables
- An operating manual including assembly instructions, an electrical connection diagram and a spare parts list in different languages
- EU Declaration of Conformity

## Additionally included in the standard scope of delivery for the MEATLINE O version

- A separator unit including all pneumatic parts (pressure regulator, water separator, etc.)
- Advanced system monitoring

## Additionally included in the standard scope of delivery for the MEATLINE + version

- Twist-off extension

## Technical data

- |                          |  |
|--------------------------|--|
| ■ Operating voltage:     | 100 to 240 VAC, 50/60 Hz   |
| ■ Power consumption:     | max. 75 W  |
| ■ Device fuse:           | 1,25 A (slow-blow fuse), 5x20 mm according to DIN  |
| ■ Degree of protection:  | IP 69 K  |
| ■ Ambient temperature:   | -5° C to +50° C  |
| ■ Storage temperature:   | -10° C to +60° C   |
| ■ Relative humidity:     | 0 to 95 % (without water condensation)   |
| ■ Conveying speed:       | max. 1.2 m/s   |
| ■ Separation time:       | adjustable from 0.1–30 s   |
| ■ Power supply:          | approx. 2.5 m cable with a Schuko plug<br>(the US version comes with a standard US plug) |
| ■ Compressed air supply: | 7–10 bar (up to 40° C)   |
| ■ Operating pressure:    | 6 bar  |
| ■ Material:              | Stainless steel, sand-blasted  |

### Available accessories

- |                          |  |   |
|--------------------------|--|---|
| <input type="checkbox"/> | Optical signal device                    | Indicator lamp  |
| <input type="checkbox"/> | Acoustic signal device                   | Warning siren   |
| <input type="checkbox"/> | WLAN                                     | WLAN module for wireless connection to networks, etc.                               |
| <input type="checkbox"/> | Mechanical connection adapter            | Device inlet<br>Good material outlet  |
| <input type="checkbox"/> | Electronic control adapter <sup>1</sup>  | coordinates the interaction between the filler, the clipper and the metal separator |
| <input type="checkbox"/> | Test piece addition station <sup>1</sup> | mounted on the device inlet<br>(for regular functional tests)                       |

<sup>1</sup>Compare recommended accessories (optional)

### Additionally available accessories for the MEATLINE O version

- |                          |   |   |
|--------------------------|---|---|
| <input type="checkbox"/> | Reject material collection container <sup>1</sup> | lockable stainless-steel container (compliant with IFS)<br>Bracket for E2 box |
|--------------------------|---|---|

<sup>1</sup>Compare recommended accessories (optional)

### Special designs

- Special voltage
- Manufacturer-neutral delivery with individual labeling
- Special sizes for ham production as per DN 80 and DN 100 (see the separately available MEATLINE 07-80/100 data sheet)

## Recommended accessories (optional)

The **electronic control adapter** coordinates the interaction between the filler, the clipper and the metal detector. Different adapter designs are available for the different makes and types of fillers. We need the following information to specify the correct adapter: filler make / filler type / machine number and/or serial number.



Example: A control adapter for a Handtmann vacuum filler



A **station for the addition of test pieces** at the device inlet facilitates regular testing of the device. During testing, a test piece containing a reference metal ball is pressed into the sausage mass through an opening at the inlet adapter. If the test result is positive, the metal separator separates the test piece along with a small quantity of the sausage mixture via the reject outlet. This is used to verify that the metal separator is fully functional. Older devices can also be retrofitted with a station for the addition of test pieces.

The **reject material collection container** made of stainless steel is robust and also resistant to fracture and breakage. A lockable lid ensures that only authorized personnel can open/empty the container. Thus, the reject material collection container fulfills the requirements of all common quality standards. Older models can also be retrofitted easily. Alternatively, a bracket for E2 boxes is available, as shown in the illustration on the right.



If a twist-off gear needs to be connected, the device can be equipped with a **twist-off gear extension**.

Dimensions of the standard MEATLINE device

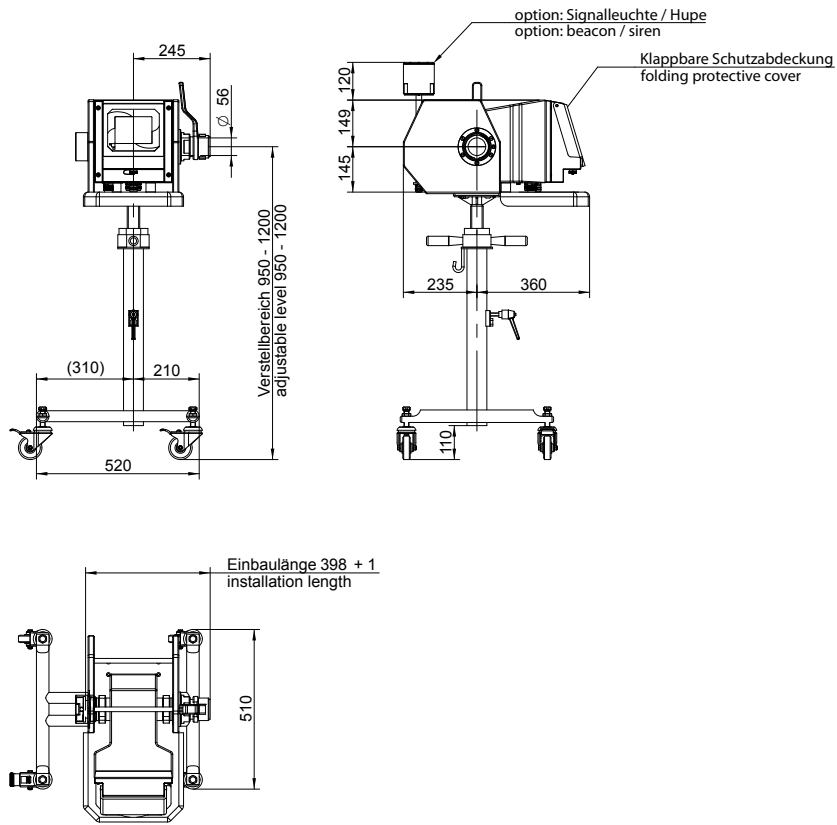

Dimensions of the MEATLINE + version

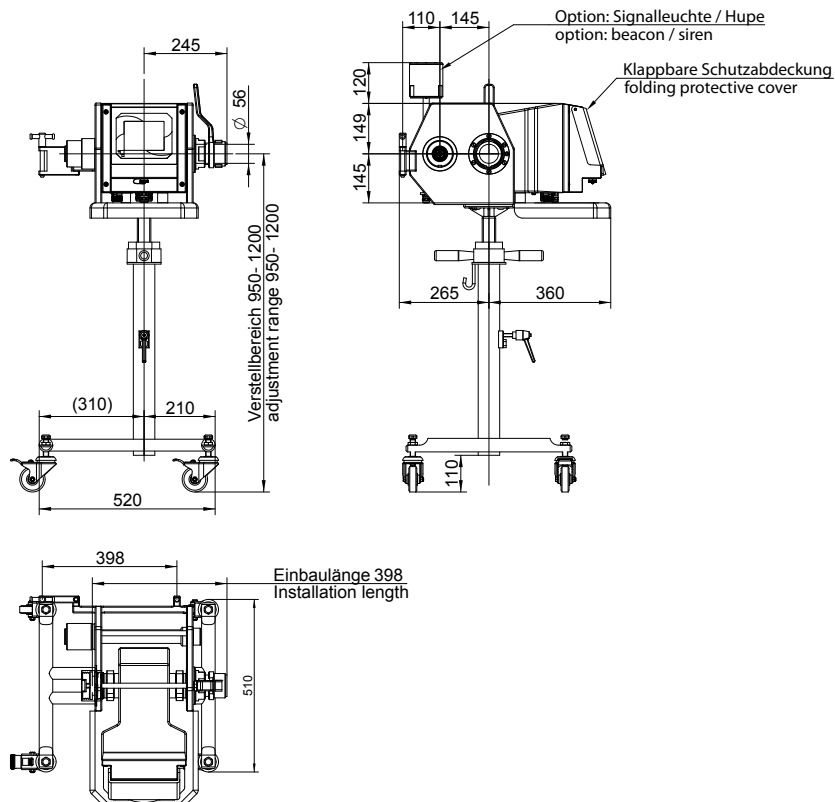

## Dimensions of the MEATLINE O version

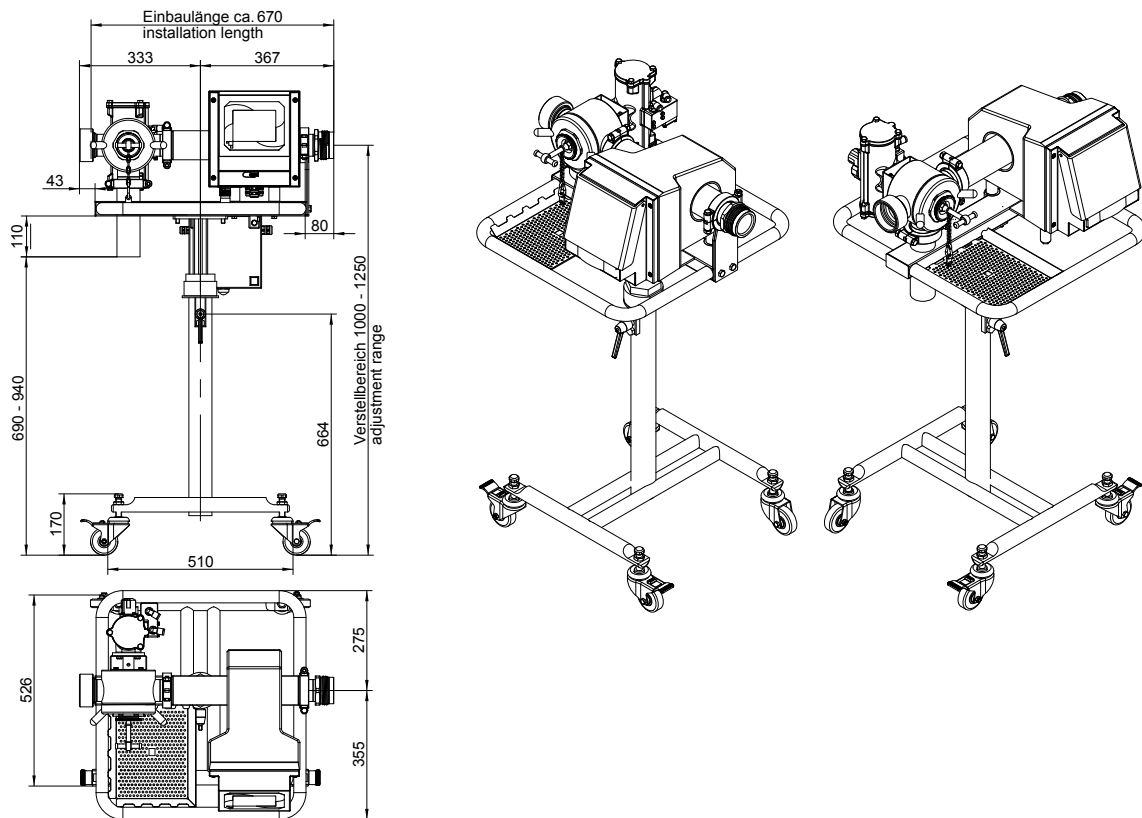

## Dimensions of the MEATLINE O version with a test piece addition station

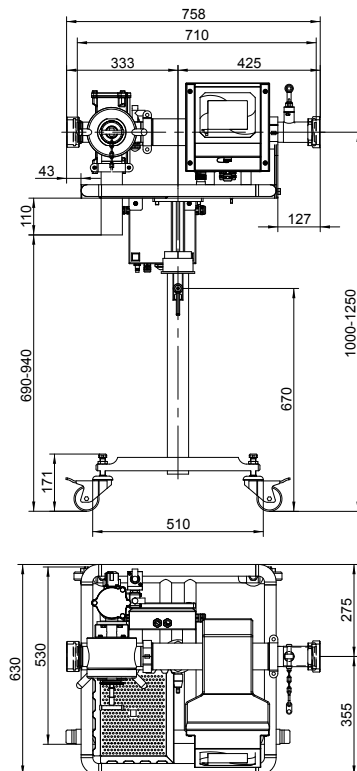

The displayed connections are examples that may differ depending on the filler and clipper manufacturers.

## Evaluation electronics AMD 07

Advantages that will convince you too!

**Unlimited flexibility** thanks to network-enabled system components. The metal sensor, control panel and control unit communicate via Ethernet and can be combined as required. If the metal sensor is integrated in a device, individual system components can be omitted entirely. Distance is no longer a problem. The highest detection accuracy and maximum operational reliability are guaranteed at all times.

**Automated setup routine** with a noise measurement function and automatic sensitivity control.

**Fully automatic product effect fade-out** through real product parameter measurement made possible after a single measurement cycle.

**Dynamic auto-tracking** (product tracking) guarantees maximum scanning sensitivity even if the product effects have been changed due to production-related requirements.

**Multi-functional filtration system** (a highly selective digital filter and a dynamic response filter) for smooth operation even in harsh industrial environments.

**Auto-balance** is a fully automated component that works continuously to compensate for disruptive environmental influences (e.g. temperature fluctuations) and ageing-related changes to the search coil.

**Precise metal detection** for metal parts of various sizes.

**Touch-screen control panel** – the maximum amount of information combined with a convenient and readily accessible user interface! The 5.7" VGA color touch-screen with backlighting offers enough space for the clearly legible display of various types of information, such as parameter data sets or logging data. Input key-pads and other operating tools are dimensioned generously and laid out in a straightforward manner. Very easy operation thanks to clearly defined operating structures and a freely selectable operating language.

**Active quality assurance** through SMD components, because they not only save space, but also offer top quality and maximum reliability for our users. Faulty component placement is largely ruled out thanks to a fully automated component installation process. In addition, each circuit board is checked meticulously for defects (100% testing) and aged artificially. All **Bunting** products are CE-compliant and developed in accordance with the relevant technical guidelines and standards such as EN, DIN and UVV.

**Self-monitoring system** for ongoing control of device functions and for monitoring of the separation process. Error output via a relay and additionally via a text message.

**Power failure-proof parameter memory** for 500 different products. A complete data set with all configuration parameters (sensitivity, duration of separation, etc.) is assigned to each product. Time-related data is displayed in real time. Different product names can also be entered.

**Detector test function** - can be performed either manually or automatically. In automatic mode, the device reports automatically when the test is to be carried out. The corresponding test results are documented in the printer log along with time and date stamps.

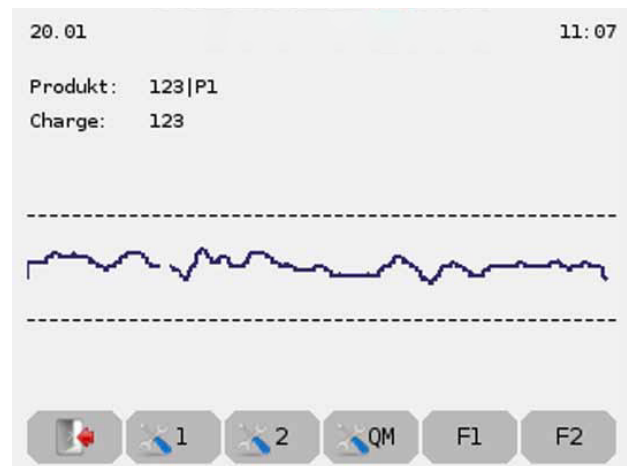



**USB storage support** for portable data storage media. The default configuration features a USB socket which is compatible with all standard USB storage devices. Modern media offer sufficient space for the storage of all configuration and product parameter data, as well as event data.

**Data interfaces** for various tasks. The metal detector features various data interfaces. An additional interface (Ethernet) is freely available.

**Metal event and piece counter** - shown on the display and/or in the printer log.

**Comprehensive user management** Guaranteed protection against unauthorized access to the metal detector through intelligent user management. Individual access rights for authorized persons with a personal login password (user ID).

## Operating elements

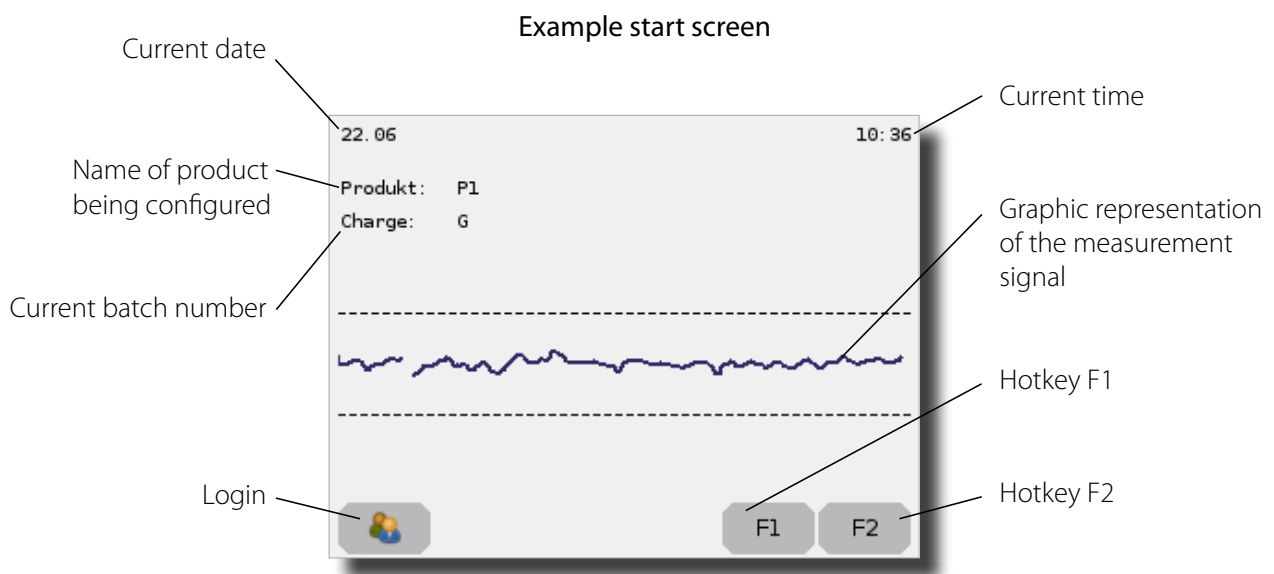

## Electronics housing

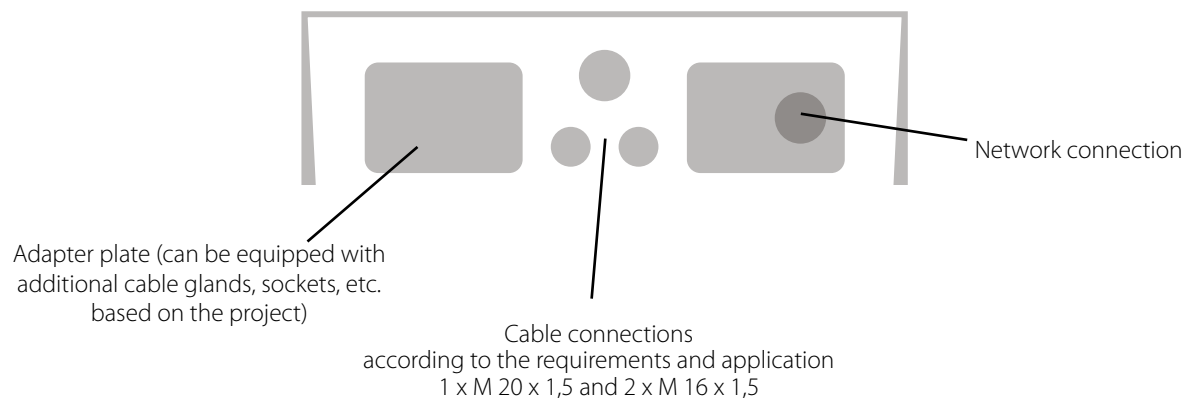

Layout plan

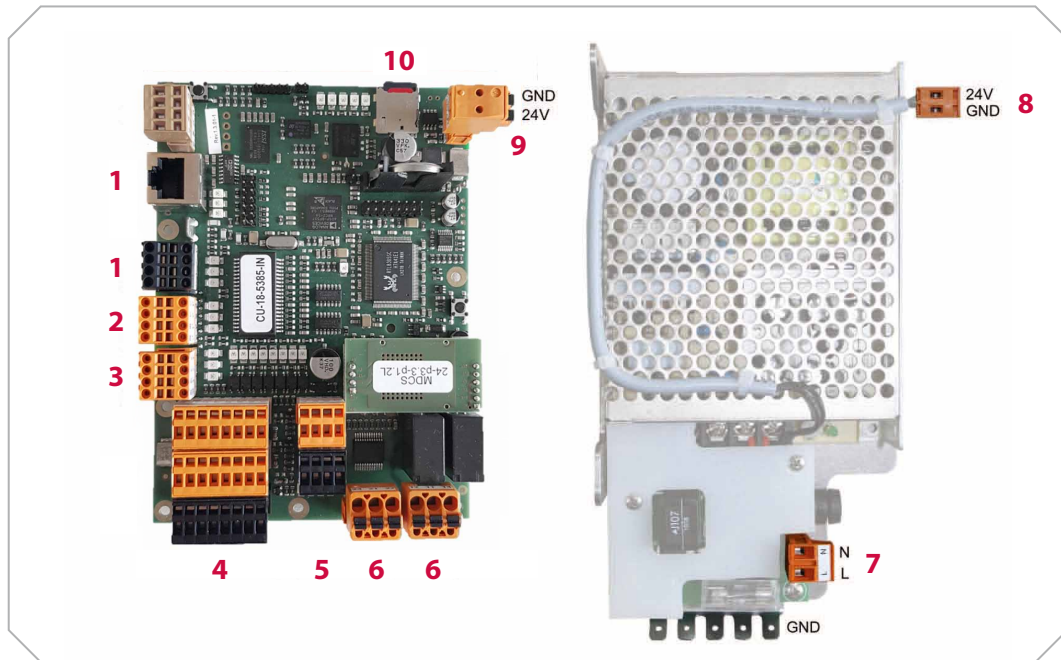

- 1 Ethernet interface for networking (e.g. mesuNET) or autoTEST
- 2 Ethernet connection, sensor unit (used at the factory)
- 3 Ethernet connection, display unit (used at the factory)
- 4 Eight freely programmable inputs (24V DC)

*The following assignments are possible:*

- Reject unit - activation position
- Reject unit - reset position
- Reject unit - product rejection
- Reject unit - test
- Pressure monitoring
- Encoder (only possible at inputs I1 to I4)
- Light barrier
- Reset external
- Metal external
- Reject check sensor
- Disable detection
- Reject unit level sensor
- Reject unit external control
- Collecting container
- External info message
- Test request external

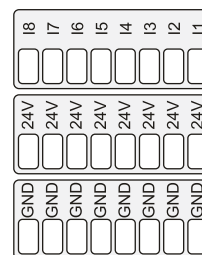

## 5 Four freely programmable outputs (24 V DC)

The following assignments are possible:

Metal	Conveyor control
Pinch valve 1	Pinch valve 2
Trigger output	Collecting container
Reject unit	Detector ready
Detector test	Test piece detected

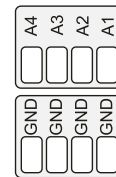

Max. current load of all outputs and inputs  $I_{\text{total}} \leq 300\text{mA}$  !

## 6 Two freely programmable relays (potential-free)

Relay 2 (switches by default in the event of an error)  
 potential-free changeover contact,  
 switches when the system monitoring is triggered (normal operation)  
 Max. contact current capacity: 250 V/3 A

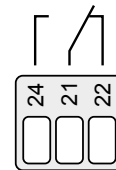

Relay 1 (switches by default if metal is detected)  
 potential-free changeover contact, switches when metal is detected  
 Max. contact current capacity: 250 V/3 A  
 Pulse length (auto reset): 0.1 s to 30 s (adjustable)  
 Pulse length (manual reset): Continuous signal until the reset button is pressed

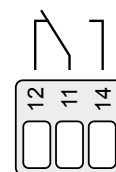

## 7 AC power supply connection

## 8 24V DC power supply / output (used at the factory)

## 9 24V DC power supply / input (used at the factory)

### **Service and Calibration**

Bunting service engineers are available at short notice to service and calibrate our full range of detectors in the UK and overseas. Bunting offers 3 levels of protection designed to provide specific services to optimise the performance and lifespan of metal detection equipment

### **Pro-Start™**

Pro-Start™ commissioning coverage ensures that a metal detector performs to company expectations from its first day on the job. A factory-trained service technician will be on-site to verify the installation, calibrate the metal detector to achieve top performance and train personnel. Pro-Start includes a calibration label for the detector, a complimentary set of test pieces (specify size and type on purchase) and a detailed calibration record for company files. It also extends the original one-year factory warranty to two years and includes two years of phone-based technical support.

### **Pro-Maintenance™**

Pro-Maintenance™ keeps the metal detector operating like new, which is critical, considering the impact of poor performance on customer satisfaction and other consequences. It provides either annual (Gold plan) or biannual (Platinum plan) visits by factory-trained service technicians to service and calibrate the metal detector and ensure the system is running the latest accurate software. The Pro-Maintenance plan also includes significant parts and labour discounts on any needed spares and repair work, on-site training for personnel during service & calibration visits and two years of phone based technical support.



Burnt Meadow Road, Redditch, Worcestershire, UK, B98 9PA

Tel: +44(0)1527 65858

E-Mail: [sales.redditch@buntingmagnetics.com](mailto:sales.redditch@buntingmagnetics.com) • [www.mastermagnets.com](http://www.mastermagnets.com)